

Granite X500IP Beam

WATERPROOF BEAM LIGHT

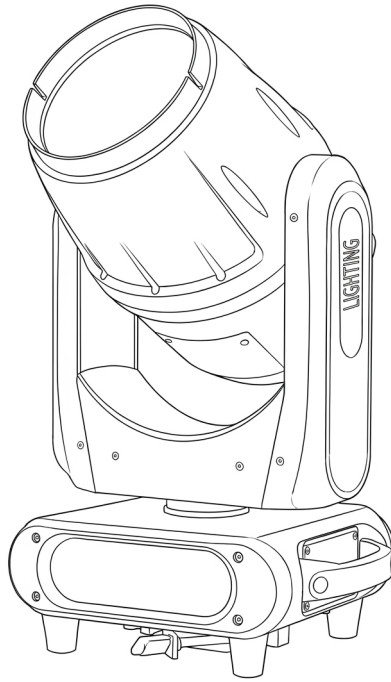

FXLIGHTING
FX-LIGHTING.COM

USER MANUAL

Please read carefully before use

TABLE OF CONTENTS

1. Precautions and Installation	3
1.1 Statement	3
1.2 Maintenance	3
1.3 Product Precautions	3
1.4 Product Introduction	4
1.5 Signal Cable Connection	5
1.6 Lamp Installation	5
2. Control Panel	6
2.1 Button Description	6
2.2 Main Menu	6
2.2.1 Settings	6
2.2.2 Manual Control	7
2.2.3 Information	7
2.2.4 Factory	8
3. Channel Functions	9
3.1 Channel Table — 19-channel mode (Mode 1)	9
3.2 Channel Table — 17-channel mode (Mode 2)	11
4. Technical Parameters	13
5. Common Faults	14

1. PRECAUTIONS AND INSTALLATION

1.1 Statement

Thank you for choosing our products! This product was shipped in perfect condition and packaged intact. For safe and effective use, please read this instruction manual carefully and completely before using this product. This manual contains important information on installation and operation. Please install and operate according to the instructions in this manual. Please keep this manual in a safe place for easy reference. Our company assumes no responsibility for any damage to the lamp or other performance issues caused by personal failure to follow this manual during installation, use, or maintenance.

This manual is subject to technical changes without prior notice.

1.2 Maintenance

- ▶ Disconnect the power supply before performing maintenance.
- ▶ Keep the lamp dry and avoid operating in humid environments.
- ▶ Intermittent use will effectively extend the life of the lamp.
- ▶ To ensure good ventilation and lighting effects, be sure to clean the fan, fan screen, and lens regularly.
- ▶ Do not use organic solvents such as alcohol to wipe the lamp housing to avoid damage.

1.3 Product Precautions

- ▶ This lamp is for professional use only.
- ▶ Before operation, ensure that the power supply voltage matches the power supply voltage required by the equipment.
- ▶ Do not place this product in a place where it is easily loose or easily vibrated.
- ▶ During use, if the lamp malfunctions, stop using the lamp immediately.
- ▶ To ensure the service life of the product, do not place this product in a humid or leaking place, and do not operate it in an environment with a temperature exceeding 60 degrees.
- ▶ When the bulb is in use, the power supply voltage should not vary by more than $\pm 10\%$. If the voltage is too high, the life of the bulb will be shortened, and if the voltage is too low, the bulb will be affected. Light color.
- ▶ After a power outage, allow the lamp to cool down completely for 20 minutes before reconnecting.
- ▶ Regularly inspect the rotating parts and adhesive accessories of the lamp. If loose or shaking, tighten them immediately to prevent accidents.
- ▶ To ensure the normal use of this product, please read these instructions carefully.

1.4 Product Introduction

Parameter	Value
Voltage	AC90V-240V
Frequency	50Hz / 60Hz
Power	580W
Light Source	420W Bulb
Dimming	0-100% Dimming
Fog	0-100% Fog
Colorful	0-100% Colorful
Focus	Electronic Focus
Strobe	Dual-lens Strobe (0.5-9 times/second)
Optical Lens	180mm 2-in-1 High-Precision Combination Optical Lens
Horizontal Scan	540° Electronic Error Correction
Vertical Scan	270° Electronic Error Correction
Channel Mode	18CH
DMX Connector	3-Pin XLR
Operation Mode	DMX512 / Auto / Voice Control
Display	LCD
Prism Plate	Any two prism effects can be combined to create dynamic prism effects, and can be rotated in both directions to switch effects
Colors	1 fixed color plate, 13 Color + white light, rainbow effect with adjustable speed, half-step color effect
Fixed Pattern	1 fixed pattern wheel, 13 patterns + white light, bidirectional variable speed rotation
Dimensions	370mm × 270mm × 640mm
Light Weight	22 kg
Protection Level	IP65

1.5 Signal Cable Connections

Lighting fixtures feature standard 3- or 5-pin XLR sockets for DMX input and output. Use shielded twisted-pair signal cables designed for DMX 512. The typical signal cable distance is 150 meters. For longer-distance signal transmission, a DMX 512 signal amplifier is required. Connect a shielded twisted-pair cable from the controller's DMX output to the DMX input of the first fixture. Then, connect the DMX output of the first fixture to the DMX input of the second fixture, and so on, until all fixtures are connected. Install a termination plug on the last fixture's 3-pin output jack in each connection. (Solder a 4/1W, 120Ω resistor between pins 2 and 3 of the 3-pin XLR connector.)

IMPORTANT: The wires must not touch each other or the metal housing.

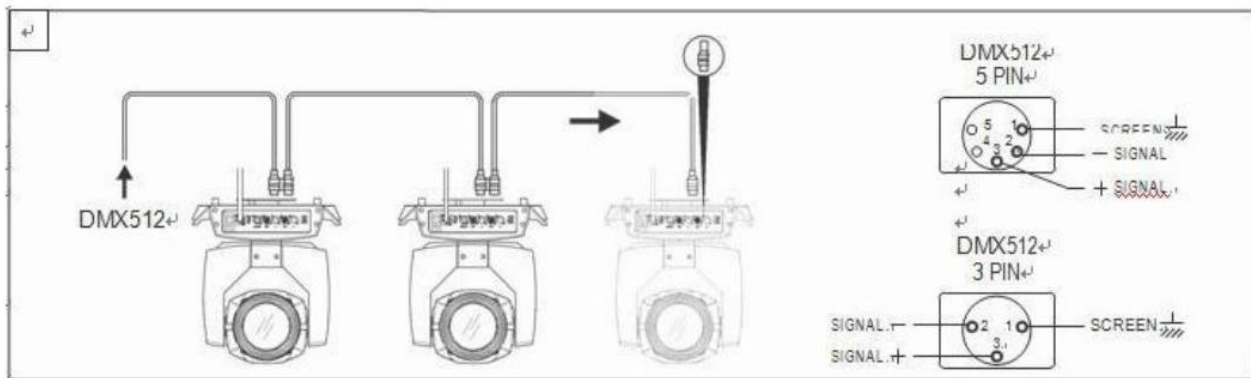

Figure 1 — DMX signal line connection diagram

Calculation method for fixture starting address:

The starting address of the current fixture is equal to (the starting address of the previous fixture) + (the number of channels in the fixture).

- ▶ Note 1: The starting address of the first fixture is A001.
- ▶ Note 2: The basic number of channels in the controller should be greater than or equal to the total number of channels in use.
- ▶ Note 3: When using any controller, each fixture must have its own starting address. If the starting address of the first fixture is set to A001 and the number of channels is 16, then the starting address of the second fixture should be set to A017; the starting address of the third fixture should be set to A033; and so on. (This setting method also needs to be determined by different controllers.)

1.6 Luminaire Installation

Luminaires can be placed horizontally, hung at an angle, or hung upside down. When hanging at an angle or upside down, particular attention must be paid to the installation method. As shown in Figure 2, before positioning the luminaire, ensure the stability of the installation site. When hanging the luminaire

upside down, ensure that the luminaire does not fall from the support frame. A safety rope must be passed through the support frame and the luminaire handle to assist in the hanging process. This ensures safety and prevents the luminaire from falling or sliding. During installation and commissioning, pedestrians are prohibited from passing underneath the luminaire. Regularly check the safety rope for wear and the hook screws for looseness. Our company assumes no responsibility for any consequences resulting from the luminaire falling due to an insecure hanging installation.

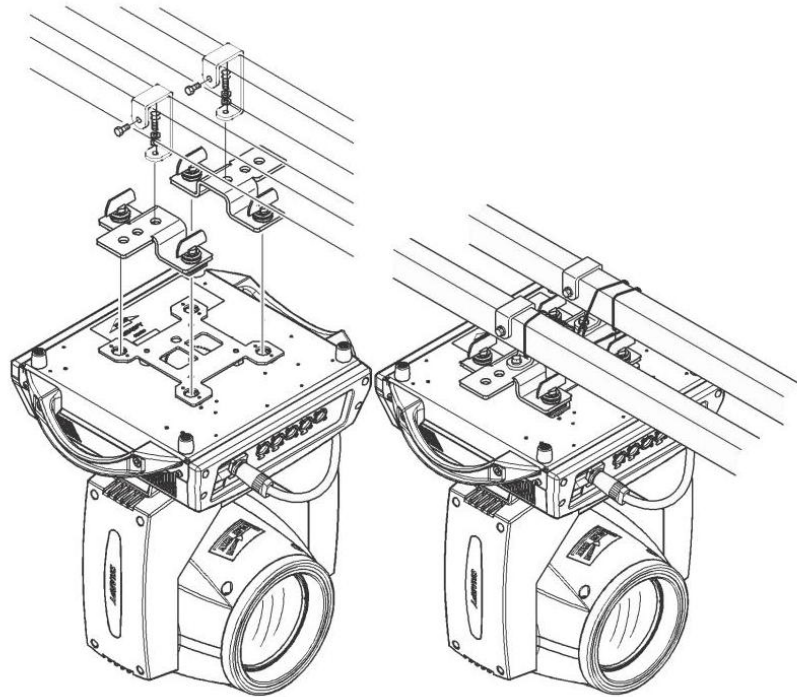

Figure 2 — Schematic diagram of inverted lamp

2. CONTROL PANEL

2.1 Button Description

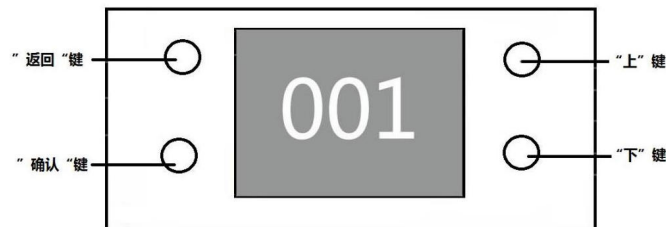

Figure 3 — Panel button description diagram

The following describes how to use the buttons:

1. If you are not currently on the main screen, press the **"Back"** button (one or more times) to return to the main screen.
2. On the main interface, press the **"Up"** or **"Down"** key to select the "Settings" button.
3. Press the **"OK"** button to enter the "Settings" interface.
4. In the "Settings" interface, press the **"Up"** or **"Down"** key to select "Menu".
5. Press the **"OK"** button to enter the editing state.
6. Press the **"Up"** or **"Down"** key to modify the menu.
7. Press the **"OK"** button to save and exit the editing state.

2.2 Menu Description



Figure 4 — Main menu diagram

2.2.1 Settings

Option	Value	Description
Run	DMX	Slave state: receiving DMX signals from the console or host
	Scene self-propelled	Host status: self-propelled and sending DMX signals to slaves
	Voice control	—
Scene Settings	—	20 scenes can be manually set
DMX Address	1~512	Press "OK" to enter the editing state. At this time, the hundreds place is selected, press "Up" / "Down" key to change the address code. Press "OK" again to select the tens digit to edit. Press "OK" again to select the units digit to edit. Press it again to exit the editing state.
Light bulb	Off	Guanpao
	On	Bright Bubbles
Motor reset	Switch	—
	Turn on the lamp to reset	—
Aisle	Standard 16CH	Standard 16 channel mode
Language	English	Set to English interface
	Chinese	Set to Chinese interface
Screen flip	Off	Front display
	On	Screen reverse display
X Invert	Switch	X motor direction rotates 180 degrees
Y Invert	Switch	Y motor direction rotates 180 degrees
XY Swap	Switch	Swap XY axis channels (including fine adjustment)
XY encoder	On	Use encoder (optocoupler) to detect loss of step and automatically correct position
	Off	

Option	Value	Description
		Correcting position without using an encoder (photocoupler)
DMX signal	Open	Continue to run as is
	The	The motor returns to its original position and stops running
Light bulb on startup	Switch to keep clear	—
	Turn	Light bulb after power on
Color Linear	On	Color wheel linear change
	The switch	Color wheel nonlinear change, half color change
Clear scene data and restore to default	Open	Clear scene data
	Close	Press the "OK" button to see the confirmation dialog box, press the "OK" button again to resume. Restore default settings.

Scene Setting Instructions

Option	Value	Description
Scene	01-20	You can select scene 1 to scene 20 for programming
Scene time	0-255	Set the current scene running time, up to 255 seconds
Operation switch	0-255	The default setting is on, which will be executed when the system is running automatically. If it is set to off, it will skip the previous scene and run the next scene.
Scene	0-255	Set the console value
Scene time	0-255	—
Scene runs	0-255	—
1. Color wheel ... 15. Atomization/colorful	0-255	—

2.2.2 Manual Control

This interface is used to control the current lamp (does not receive DMX signals), corresponding to the channel. For details, refer to the channel table.

Options	Value	Description
1CH.	0~255	Press "OK" key to enter the editing state. At this time, the hundreds place is selected.
...	0~255	Press the "Up" and "Down" keys to change the channel value. Press the "OK" key again.
15CH.	0~255	Press the "OK" key to select the tens digit to edit. Press the "OK" key again to select.
...	0~255	Edit the middle digit. Press again to exit the editing state.

2.2.3 Information

Options	Description
Ver	Software version
DIS	Display board software version
MT	Motor board software version
Time information	1. Total bright bubbles Record the cumulative bright bubble time
	2. Total usage Record lamp usage time
System Error	If the red ERR indicator light is on, it means the lamp is operating incorrectly. You can enter the sub-interface to view the details. Press the "Clear" button to clear the error log.
Blower speed Hall	Displays the current blower speed
Status	11100010 — When magnetism is detected, it is 0; otherwise, it is 1
X-coded step value	When walking in the forward direction, the step value should increase, and when walking in the reverse direction, the step value should decrease. 0000 — The value is normal every time you go to the same point.
Y-coded step value	When walking in the forward direction, the step value should increase, and when walking in the reverse direction, the step value should decrease. 0000 — The value is normal every time you go to the same point.
Permission duration	9999 is not encrypted; other values can be encrypted

A. Error Message Description

Error	Cause / Solution
-------	------------------

MT board connection failed

Error	Cause / Solution
	The motor board did not respond. There is a problem with the serial communication line connecting the display board and the motor board, or there is a problem with the motor board.
X axis reset failed	There is something wrong with the X axis photoelectric switch, or the X axis motor or motor board.
Y axis reset failed	There is something wrong with the Y axis photoelectric switch, or the Y axis motor or motor board.
X-axis Hall error	X-axis Hall, or motor board has problems.
Y axis Hall error	Y axis Hall, or motor board has problems.
Color wheel reset failure	There is a problem with the color wheel Hall or the color wheel motor.
Pattern wheel reset failure	There is a problem with the pattern wheel Hall or the pattern wheel motor.
Focus reset failed	Focus Hall, or there is a problem with the focus motor.
The bulb control fails	The bulb fails to light up or extinguish. There is a problem with the igniter or bulb.

2.2.4 Factory

Option		Description
Calibration	Data Download	After replacing the display board, download the calibration of the original display board from the motor board data.
	X-axis	After entering the sub-interface, you can adjust the reset of the X-axis, Y-axis and other motors. Position to compensate for the error in hardware installation and adjust the range. -128~+127, +0 means no adjustment.
	Y-axis	
	Color	—
	Pattern	—
	Focusing	—
	Dimming	—
	Prism 1 Zero Point	—
	Prism 1 Stroke	—
	Prism 2 Zero Point	—
	Prism 2 Stroke	—
Atomization / Zero point / Atomization stroke	—	
Colorful mirror stroke reset	Close	—
	On	Data restore default value
X Hall	Off	X Hall error off
	On	X Hall error switch, Y Hall error off. On, Y Hall error switch.
Half power function	Off	No half power
	On	With half power function

3. CHANNEL FUNCTIONS

3.1 19-Channel Mode (Mode 1)

CH	Value	Function
1	000-255	Horizontal 0°→540°
2	000-255	Horizontal fine-tuning
3	000-255	Vertical 0°→260°
4	000-255	Vertical fine adjustment
5	000-255	X/Y axis speed from fast to slow
6	000-007	Color wheel opening
	008-011	Color 1
	012-015	Color 2
	016-019	Color 3
	020-023	Color 4
	024-027	Color 5
	028-031	Color 6
	032-035	Color 7
	036-039	Color 8
	040-043	Color 9
	044-047	Color 10
	048-051	Color 11
	052-055	Color 12
	056-059	Color 13
	060-063	Color 14
	064-069	White
	070-093	Half-step colors (Color 1+2, 2+3 ... 13+14, 14+White)
	094-127	White
	128-189	Anti-clockwise rotation, from fast to slow

CH	Value	Function	
	190-193	Stop	
	194-255	Clockwise rotation, from slow to fast	
	7	000-007	Pattern wheel opening
008-011		Pattern 1	
012-014		Pattern 2	
015-018		Pattern 3	
019-021		Pattern 4	
022-025		Pattern 5	
026-028		Pattern 6	
029-032		Pattern 7	
033-035		Pattern 8	
036-039		Pattern 9	
040-042		Pattern 10	
043-049		Pattern 11	
050-056		Pattern 12	
057-063		Pattern 13	
064-127		Patterns 1-13 shakes, from slow to fast	
128-189		Clockwise rotation, from fast to slow	
190-193		Stop	
194-255	Anti-clockwise rotation, from slow to fast		
8	000-007	Homogenizer plate opening	
	008-131	Homogenizer plate 1	
	132-255	Homogenizer plate 2	
9	000-007	8 Prism Off	
	008-255	8 Prism On	
10	000-127	8 Prism rotation — Prism slide	
	128-189	Clockwise rotation, from fast to slow	
	190-193	Stop	

CH	Value	Function
	194-255	Counterclockwise rotation, from slow to fast
11	000-007	24 Prism switch off
	008-255	24 Prism switch on
12	000-127	24 Prism self-rotation — Prism slide
	128-189	Clockwise rotation, from fast to slow
	190-193	Stop
	194-255	Counterclockwise rotation, from slow to fast
13	000-007	Fog mirror off
	008-255	Fog mirror on
14	000-255	Focus 0% → 100%
15	000-255	Focus fine-tuning
16	000-007	Strobe close
	008-015	Open the light
	016-131	Strobe on and off, turn on slowly and quickly
	132-139	Turn on slowly and quickly
	140-181	Turn on slowly and quickly and turn off slowly
	182-189	Turn on quickly and turn on slowly and quickly
	190-231	Turn on randomly and turn on slowly and quickly
	232-255	Various strobe patterns
17	000-255	Dimming 0% → 100%
18	000-255	Dimming fine-tuning
19	000-129	No function

CH	Value	Function
	130-139	Light bulb is on
	140-149	X/Y axis reset
	150-159	Head motor reset
	160-199	No function
	200-209	All motors reset
	210-211	Pattern shortcut: Enable
	212-213	Pattern shortcut: Disable
	214-215	Color shortcut: Enable
	216-217	Color shortcut: Disable
	218-229	No function
	230-239	Light bulb off
	240-255	No function

3.2 17-Channel Mode (Mode 2)

CH	Value	Function
1	000-255	Horizontal 0°→540°
2	000-255	Horizontal fine-tuning
3	000-255	Vertical 0°→260°
4	000-255	Vertical fine adjustment
5	000-255	X/Y axis speed from fast to slow
6	000-003	Color wheel opening
	004-007	Opening
	008-011	Color 1
	012-015	Color 2
	016-019	Color 3
	020-023	Color 4
	024-027	Color 5
	028-031	Color 6
	032-035	Color 7
	036-039	Color 8
	040-043	Color 9
	044-047	Color 10
	048-051	Color 11
	052-055	Color 12
	056-059	Color 13
	060-127	Color 14
	128-189	Color wheel sliding step
	190-193	Stop
	194-255	Counterclockwise rotation, from fast to slow / Clockwise rotation, from slow to fast
	7	000-007
008-010		Pattern 1

CH	Value	Function
011-013		Pattern 2
014-016		Pattern 3
017-019		Pattern 4
020-022		Pattern 5
023-025		Pattern 6
026-028		Pattern 7
029-031		Pattern 8
032-034		Pattern 9
035-037		Pattern 10
038-040		Pattern 11
041-043		Pattern 12
044-046		Pattern 13
047-049		Pattern 14
050-052		Pattern 15
053-055		Pattern 16
056-059		White light shakes, from slow to fast
060-127		Patterns 1-16 Shakes, from slow to fast
128-255		Clockwise / Stop / Counterclockwise rotation
8	000-007	8 Prism Off
	008-255	8 Prism On
9	000-127	8 Prism rotation — Prism slide
	128-189	Clockwise rotation, from fast to slow
	190-193	Stop
	194-255	Counterclockwise rotation, from slow to fast
10	000-007	24 Prism Gate
	008-255	24 Prism open
11	000-127	24 Prism self-rotation — Prism slide
	128-189	

CH	Value	Function
		Clockwise rotation, from fast to slow
	190-193	Stop
	194-255	Counterclockwise rotation, from slow to fast
12	000-007	Strobe close
	008-015	Open light
	016-131	Strobe, from slow to fast
	132-167	Open and close quickly, from slow to fast
	168-203	Open and close quickly, from slow to fast
	204-239	Jump, from slow to fast
	240-247	Random strobe, from slow to fast
	248-255	Open light
13	000-255	Dimming 0% → 100%
14	000-255	Focus 0% → 100%
15	000-255	Focus fine-tuning
16	000-007	Fog mirror off
	008-255	Fog mirror open
17	000-129	No function
	130-139	Light bulb is on
	140-149	X/Y axis reset
	150-159	Head motor reset
	160-169	Retraction
	170-179	Homogenization
	180-199	Homogenized tablet 1 / Homogenized tablet 2
	200-209	All motors reset
	210-211	Pattern shortcut: Enable
	212-213	

CH	Value	Function
		Pattern shortcut: Disable
	214-215	Color shortcut: Enable
	216-217	Color shortcut: Disable
	218-229	No function
	230-239	Light bulb off
	240-255	No function

4. TECHNICAL PARAMETERS

Parameter	Value
Voltage	AC90V-240V
Frequency	50Hz / 60Hz
Power	580W
Light Source	420W Lamp
Dimming	0-100% Dimming
Fog	0-100% Fog
Colorful	0-100% Colorful
Focus	Electronic Focus
Strobe	Dual-lens Strobe (0.5-9 times/second)
Optical Lens	180mm 2-in-1 High-Precision Combination Optical Lens
Horizontal Scan	540° Electronic Error Correction
Vertical Scan	270° Electronic Error Correction
Channel Mode	18CH
DMX Connector	3-Pin XLR
Operation Mode	DMX512 / Auto / Voice Control
Display Mode	LCD
Prism Wheel	Any two prism effects can be combined and combined. Dynamic prism effects can be switched in both directions.
Colors	1 fixed color wheel, 13 colors + white, rainbow effect with adjustable speed, half-step color effect
Fixed Pattern	1 fixed pattern wheel, 13 Pattern + white light, can rotate at variable speed in both directions
Dimensions	368mm × 284mm × 630mm
Protection Level	IP65

5. COMMON FAULTS

For some common faults, corresponding solutions are proposed. Any problem that cannot be solved should be solved by professionals.

WARNING: Before maintaining the lamp, please disconnect the power supply.

1. The light bulb is not working

- ▶ Check whether the voltage that matches the lamp is installed.
- ▶ Check whether the lamp power supply connection or control switch has poor contact.
- ▶ Check if the power supply is insufficient.
- ▶ Check whether the DMX512 controller has sent any commands.

2. The lamp does not accept the control of the console after normal reset

- ▶ Check whether the digital start address value and function options of the lamp are correct.
- ▶ Check whether the communication control line is connected correctly, or whether the communication line is too long or has been interrupted.
- ▶ Check whether the control device is faulty and whether the signal amplifier connected in series is faulty.
- ▶ Check whether the communication line is too long or there is interference from other devices.
- ▶ Optimize wiring, shorten the length of control signal lines, and separate high-voltage and low-voltage lines.
- ▶ Add a signal amplifier.
- ▶ The signal line uses high-quality shielded twisted pair cable.
- ▶ Connect the signal terminal resistor (120 ohms) to the end of the lamp.

3. The lamp cannot be turned on

- ▶ Check whether the power supply parameters are consistent with the lamp.
- ▶ Check if the lamp has poor contact due to deformation, vibration of internal parts, moisture, etc. during long-distance transportation or fall off.
- ▶ Please check whether the wires and connectors inside the lamp are loose or not.
- ▶ Check whether the electronic components of the lamp (such as electronic transformer, PCB board, motor control board, etc.) are loose, short-circuited, or damaged. Burnout phenomenon.

4. The X-axis or Y-axis of the lamp does not move normally during operation

- ▶ Check each step one by one according to the previous step.
 - ▶ Check whether the drive belts corresponding to the X and Y axis directions in the lamp are falling off or broken.
-

- ▶ Check whether the data feedback receiver (optocoupler) corresponding to the X and Y directions in the lamp is damaged.
 - ▶ Restart the device to reset it.
-
-

